

ARIMITSU

PROVEN PLUNGER PUMPS

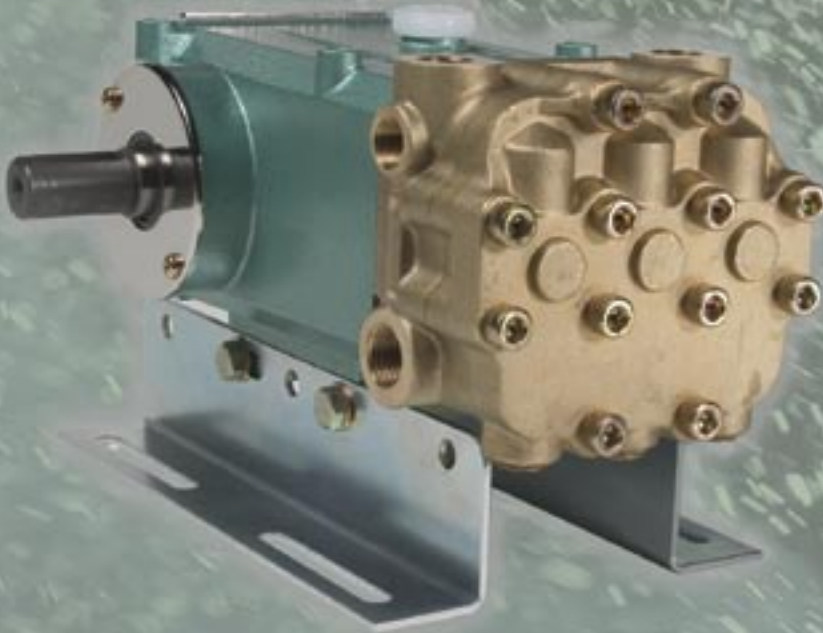

5 Series

Model 516

FEATURES

- Triplex pumps provide smooth liquid flow
- Liquid cooled, low drag seals provide long life, improved suction, higher efficiency and longer dry running without damage
- Balanced flow crankcase design and precision machining ensures uniform lubrication and quiet operation
- Manifold is designed and machined to guarantee superior fluid flow
- Interchangeable valves for maintenance ease
- Zero-clearance exclusionary seals protect crankcase

QUALITY

- 100% stainless steel valve assemblies deliver greater temperature and chemical handling abilities
- Precision ground ceramic plungers utilize a proprietary material blend for long life and increased thermal shock resistance
- Forged brass manifolds offer strength and corrosion resistance
- Proprietary, proven seal blend maximizes life and increases maintenance intervals
- Oversized crankshaft bearings for long life and quiet operation

MAINTENANCE

- No special tools required for repair or maintenance
- Fluid end is easily serviced without entering crankcase
- Easy access seal case and valve assemblies
- Seals require no adjustment

SPECIFICATIONS

Model 516	US	METRIC
Flow	4 gpm	15 lpm
Pressure	2300 psi	160 bar
RPM	950	950
Inlet Pressure	-5 to 70 psi	0-5 bar
Alternative specification		
Flow	5 gpm	19 lpm
Pressure	2000 psi	140 bar
RPM	1200	1200
Inlet Pressure	Flooded to 70 psi	0-5 bar
Inlet	1/2" NPT	1/2" NPT
Outlet	3/8" NPT	3/8" NPT
Oil requirement	19 oz.	.55 L
Shaft Dia.	.866"	22 mm
Max Liquid Temp.	175°F	80°C
Shaft Location	L or R	L or R
Weight	21 lbs.	9.5 kg

Determining Pump RPM	$\frac{\text{Rated GPM}}{\text{Rated RPM}}$	=	$\frac{\text{"Desired" GPM}}{\text{"Desired" RPM}}$
Determining Required HP	$\frac{\text{GPM} \times \text{PSI}}{1460}$	=	Electric Brake H.P. Required
Determining Motor Pulley Size	$\frac{\text{Motor Pulley OD}}{\text{Pump RPM}}$	=	$\frac{\text{Pump Pulley OD}}{\text{Motor RPM}}$

Parts List

REF. #	PART NUMBER	PART NAME	MATERIAL	QTY
F01	02581010100A	MANIFOLD, PORTED	FORGED BRASS	1
F05	02585012001	SEAL RETAINER	BRASS	3
F06	02585014000A	SEAL ASSEMBLY		3
F07	<i>(included in F06)</i>	BACKING RING	FP	3
F08	<i>(included in F06)</i>	V-PACKING	NBR/TEXTILE	3
F09	<i>(included in F06)</i>	VACUUM SEAL	NBR	3
F22	0120001430	SPREADER	BRASS	3
F23	0258501450	WAVE WASHER	STAINLESS	3
F25	9203B15032	O-RING, RETAINER	NBR	3
F30	0361001140	BOLT, MANIFOLD	PLATED STEEL	8
F34	0258103200	MANIFOLD, VALVES	FORGED BRASS	1
F40	0258103300	VALVE ASSEMBLY		6
F41	<i>(included in F40)</i>	SEAT	STAINLESS	6
F42	0362003340 <i>(included in F40)</i>	GASKET	NBR	6
F43	<i>(included in F40)</i>	POPPET	STAINLESS	6
F44	<i>(included in F40)</i>	SPRING	STAINLESS	6
F45	<i>(included in F40)</i>	CAGE	STAINLESS	6
F48	9201F10022	O-RING, MANIFOLD	NBR	3
F77	0130003930	PLUG	BRASS	3
P01	02560011001	BOLT, HEAD	PLATED STEEL	4
P05	0276102010	CRANKCASE	ALUMINUM	1
P07	02560020401	BACK COVER	PLATED STEEL	1
P08	0256002050	GASKET	BONDED PAPER	1
P09	9138A05015	SCREW, PHILLIPS	PLATED STEEL	8
P10	0361001110	DOWEL PIN, MANIFOLD	PLATED STEEL	2
P25	0090002320	DRAIN PLUG	FP	1
P26	0090002340	GASKET, DRAIN PLUG	NBR	1
P29	01300026000A	OIL DIPSTICK ASSEMBLY	FP	1
P31	9201B20016	O-RING, DIPSTICK	NBR	1
P37	0276101730	WATER SLINGER	NBR	3
P40	02563024000A	OIL SEAL	NBR	3
P50	02561040102	CRANKSHAFT	STEEL	1
P51	0256004020	BEARING, BALL	STEEL	2
P53	0256004030	OIL SEAL, SHAFT SIDE	NBR	1
P54	0256104430	OIL SEAL, COVER	NBR	1
P56	0130004600	CON-ROD ASSEMBLY	ALUMINUM	3
P60	02781047S0	PLUNGER ASSEMBLY		3
P61	<i>(included in F60)</i>	ROD	STAINLESS	3
P62	<i>(included in F60)</i>	PLUNGER	CERAMIC	3
P63	<i>(included in F60)</i>	SPACER	BRASS	3
P64	0121114852	GASKET	COPPER	3
P66	<i>(included in F60)</i>	BOLT	STAINLESS	3
P65	0150004900	PIN, PLUNGER	STEEL	3
P70	02560044201	COVER, BEARING	PLATED STEEL	2
P80	0120008050	SHAFT KEY, STEPPED	STEEL	1

* Material listed may be a proprietary version. Parts names without part numbers are only available within complete assemblies.

* Material codes: FP=Flouropolymer, NBR=Medium Nitrile (Buna-N), STAINLESS=Stainless Steel (300 Series)

Exploded View

Model 516

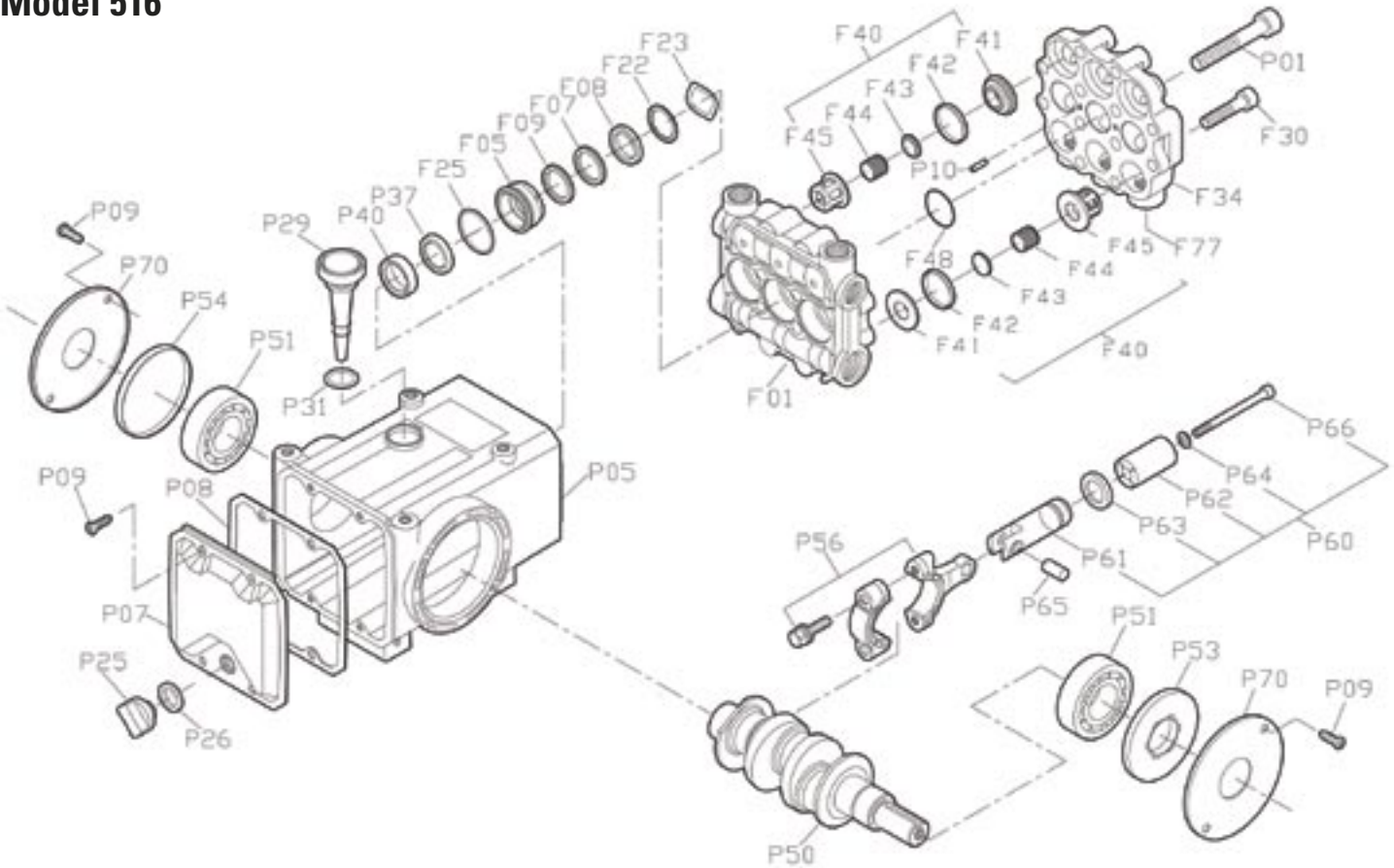

09/05

REF. #	PART NUMBER	PART NAME	MATERIAL	QTY
	30100	SEAL KIT, (INCLUDES F06, F25)	NBR	1
	30101	VALVE KIT, (INCLUDES F40, F42)	STAINLESS/NBR	1
	30102	RAIL, STND, 5 SERIES	PLATED STEEL	2
	30103	OIL, BOTTLE (32 OZ) ISO 100		1
Recommended Accessories				
	70100	6085 REGULATOR, 5-15 gpm, 1200 PSI	bronze/ceramic	1

Horsepower Requirements

Pressure (psi)

				Pressure (psi)				
	RPM	GPM	LPM	1000	1250	1500	2000	2300
516	850	3.8	14.3	2.6	3.2	3.9	5.2	5.9
	950	4.0	15.0	2.7	3.4	4.1	5.4	6.2
	1200	5.0	19.0	3.4	4.3	5.2	6.9	

ARIMITSU

PROVEN PLUNGER PUMPS

DIMENSIONS (mm/in.)

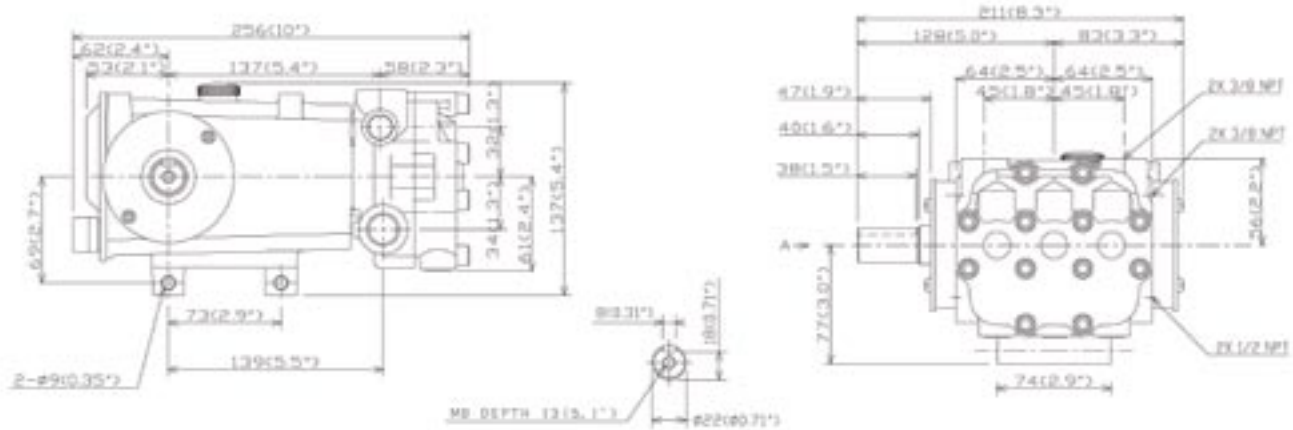

CUTAWAY

- 1 High strength, lightweight die cast crankcase
- 2 Oversized crankshaft bearings for long life and quiet operation
- 3 Forged crankshaft is machined for low friction, quiet operation and high efficiency
- 4 High strength connecting rods are tolerance matched for extended life and low friction operation
- 5 High polish stainless steel plunger rods for smooth operation and even wear
- 6 Zero clearance, polymer exclusionary seal protects pump crankcase from fluid entry and will not corrode
- 7 Proprietary blend, solid ceramic plungers for long wear and increased thermal shock resistance
- 8 Forged brass manifolds for strength and corrosion resistance, machined to optimize fluid flow and performance while extending useful life
- 9 Liquid-cooled, low drag seals provide long life, extended run-dry ability and increased suction lift
- 10 100% stainless steel valve construction provides superior protection against chemical and temperature damage
- 11 Mechanically-loaded seals require no adjustment and self-compensate for wear
- 12 Balanced flow crankcase ensures lubrication and quiet operation
- 13 Slide-in seal cases mean no special tools are required, making seal replacement easy

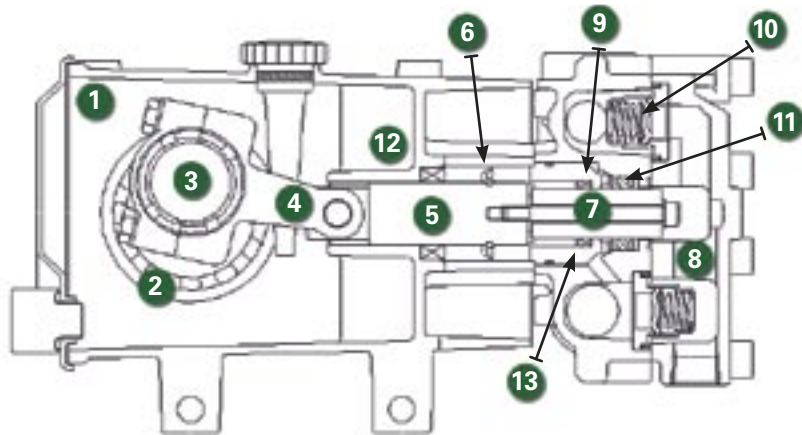

ARIMITSU

Arimitsu of North America, Inc.
 13915-H Radium Street N.W.
 Ramsey, MN 55303
 ph: 763.433.0303
 fax: 763.433.0404
 www.arimitsupumps.com

Manufactured by Arimitsu Industry Co., Ltd., of Osaka, Japan, a leading supplier of Industrial plunger pumps and systems used by Industrial leaders throughout the World.



Rev.1, Model 516, (9-05)
 Part #. 100