

## DIMENSIONS (mm/in.)

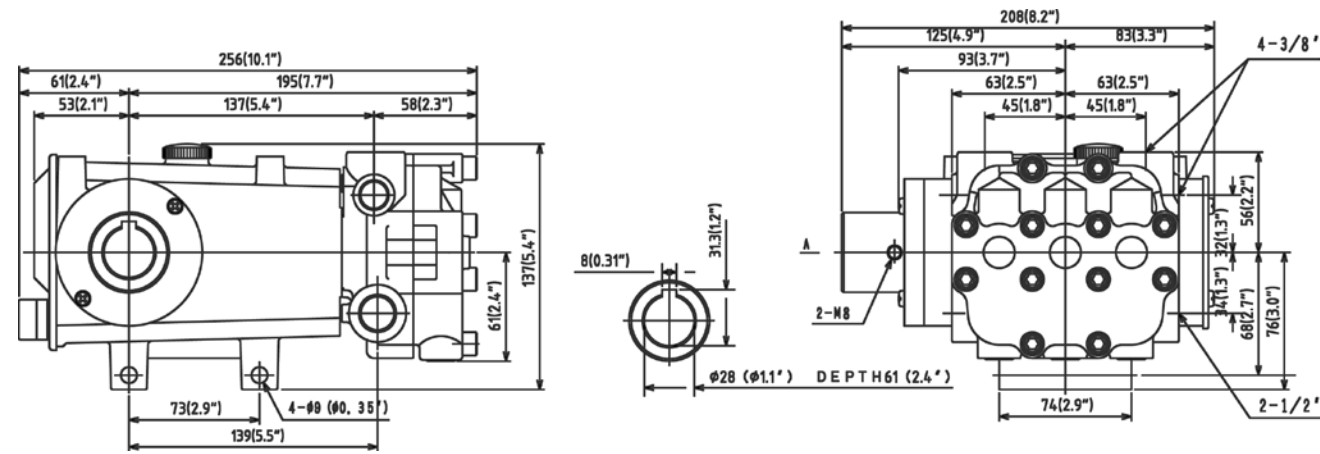

## CUTAWAY

- 1 High strength, lightweight die cast crankcase
- 2 Oversized crankshaft bearings for long life and quiet operation
- 3 Forged crankshaft is machined for low friction, quiet operation and high efficiency
- 4 High strength connecting rods are tolerance matched for extended life and low friction operation
- 5 High polish stainless steel plunger rods for smooth operation and even wear
- 6 Zero clearance, polymer exclusionary seal protects pump crankcase from fluid entry and will not corrode
- 7 Proprietary blend, solid ceramic plungers for long wear and increased thermal shock resistance
- 8 Forged brass manifolds for strength and corrosion resistance, machined to optimize fluid flow and performance while extending useful life
- 9 Liquid-cooled, low drag seals provide long life, extended run-dry ability and increased suction lift
- 10 100% stainless steel valve construction provides superior protection against chemical and temperature damage
- 11 Mechanically-loaded seals require no adjustment and self-compensate for wear
- 12 Balanced flow crankcase ensures lubrication and quiet operation
- 13 Slide-in seal cases mean no special tools are required, making seal replacement easy

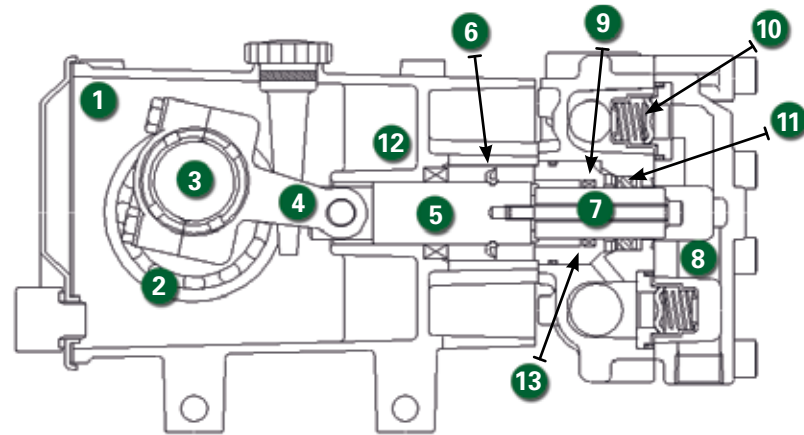

Arimitsu of North America, Inc.  
700 McKinley St. NW  
Anoka, MN 55303  
ph: 763.433.0303  
fax: 763.433.0404  
www.arimitsupumps.com

Manufactured by Arimitsu Industry Co., Ltd., of Osaka, Japan, a leading supplier of Industrial plunger pumps and systems used by Industrial leaders throughout the World.



Rev.1, 5H Series, 517, (3-07)  
Part #. 117



## Floating 5 Series Model 517

## FEATURES

- Unique mounting technology increases life and decreases noise (pat. pending)
- Triplex pumps provide smooth liquid flow
- Liquid cooled, low drag seals provide long life, improved suction, higher efficiency and longer dry running without damage
- Balanced flow crankcase design and precision machining ensures uniform lubrication and quiet operation
- Manifold is designed and machined to guarantee superior fluid flow
- Interchangeable valves for maintenance ease
- Zero-clearance exclusionary seals protect crankcase

## QUALITY

- 100% stainless steel valve assemblies deliver greater temperature and chemical handling abilities
- Precision ground ceramic plungers utilize a proprietary material blend for long life and increased thermal shock resistance
- Forged brass manifolds offer strength and corrosion resistance
- Proprietary, proven seal blend maximizes life and increases maintenance intervals
- Oversized crankshaft bearings for long life and quiet operation

## MAINTENANCE

- No special tools required for repair or maintenance
- Fluid end is easily serviced without entering crankcase
- Easy access seal case and valve assemblies
- Seals require no adjustment

## SPECIFICATIONS

Model 517	US	METRIC
Flow	5 gpm	19 lpm
Pressure	1750 psi	120 bar
RPM	1800	1800
Inlet Pressure	flooded to 70 psi	1 to 5 bar
Inlet	1/2" NPT	1/2" NPT
Outlet	3/8" NPT	3/8" NPT
Oil requirement	19 oz.	.55 L
Shaft Dia.	1.102"	28 mm
Max Liquid Temp.	175°F	80°C
Shaft Location	L or R	L or R
Weight	21 lbs.	9.5 kg

Determining Pump RPM	Rated GPM ----- Rated RPM	=	"Desired" GPM ----- "Desired" RPM
Determining Required HP	GPM x PSI ----- 1460	=	Electric Brake H.P. Required
Determining Motor Pulley Size	Motor Pulley OD ----- Pump RPM	=	Pump Pulley OD ----- Motor RPM

## Parts List

REF. #	PART NUMBER	PART NAME	MATERIAL	QTY
F01	0258101010	MANIFOLD, PORTED	FORGED BRASS	1
F05	02585012001	SEAL RETAINER	BRASS	3
F06	02585014000A	SEAL ASSEMBLY		3
F07	(included in F06)	BACKING RING	FP	3
F08	(included in F06)	V-PACKING	NBR/TEXTILE	3
F09	(included in F06)	VACUUM SEAL	NBR	3
F22	0120001430	SPREADER	BRASS	3
F23	0258501450	WAVE WASHER	STAINLESS	3
F25	9203B15032	O-RING, RETAINER	NBR	3
F30	0361001140	BOLT, MANIFOLD	PLATED STEEL	8
F34	0258103200	MANIFOLD, VALVES	FORGED BRASS	1
F40	0258103300	VALVE ASSEMBLY		6
F41	(included in F40)	SEAT	STAINLESS	6
F42	0362003340 (included in F40)	GASKET	NBR	6
F43	(included in F40)	POPPET	STAINLESS	6
F44	(included in F40)	SPRING	STAINLESS	6
F45	(included in F40)	CAGE	STAINLESS	6
F48	9203F10022	O-RING, MANIFOLD	NBR	3
F77	0130003930	PLUG	BRASS	3
P01	02560011001	BOLT, HEAD	PLATED STEEL	4
P05	0277902010	CRANKCASE	ALUMINUM	1
P07	02560020401	COVER	PLATED STEEL	1
P08	0256002050	GASKET	BONDED PAPER	1
P09	9138A050515	SCREW	PLATED STEEL	6
P10	0361001110	DOWEL PIN, MANIFOLD	PLATED STEEL	2
P11	9110B05020	BOLT	STEEL	4
P25	0090002320	DRAIN PLUG	FP	1
P26	0090002340	GASKET, DRAIN PLUG	NBR	1
P29	01300026000A	OIL DIPSTICK ASSEMBLY	FP	1
P31	9201B20016	O-RING, DIPSTICK	NBR	1
P37	0276101730	WATER SLINGER	NBR	3
P40	0256302400	OIL SEAL	NBR	3
P50	0275504010	CRANKSHAFT	STEEL	1
P51	0256004020	BEARING	STEEL	1
P53	0256004030	OIL SEAL, SHAFT SIDE	NBR	1
P54	0256104430	OIL SEAL, COVER	NBR	1
P56	0130004600	CON-ROD ASSEMBLY	ALUMINUM	3
P60	02785347S0	PLUNGER ASSEMBLY		3
P61	(included in F60)	ROD	STAINLESS	3
P62	(included in F60)	PLUNGER	CERAMIC	3
P63	0258534850	SPACER	BRASS	3
P64	0121114852	GASKET	COPPER	3
P66	9120R05060	BOLT, PLUNGER	STAINLESS	3
P65	0150004900	PIN, PLUNGER	STEEL	3
P70	02560044201	COVER, BEARING	PLATED STEEL	2
P71	0275504020	BEARING, ROLLER	STEEL	1
P71	02755044201	COVER, BEARING	ALUMINUM	1
P73	9203B15056	O-RING, COVER	NBR	1

## Exploded View

Model 517

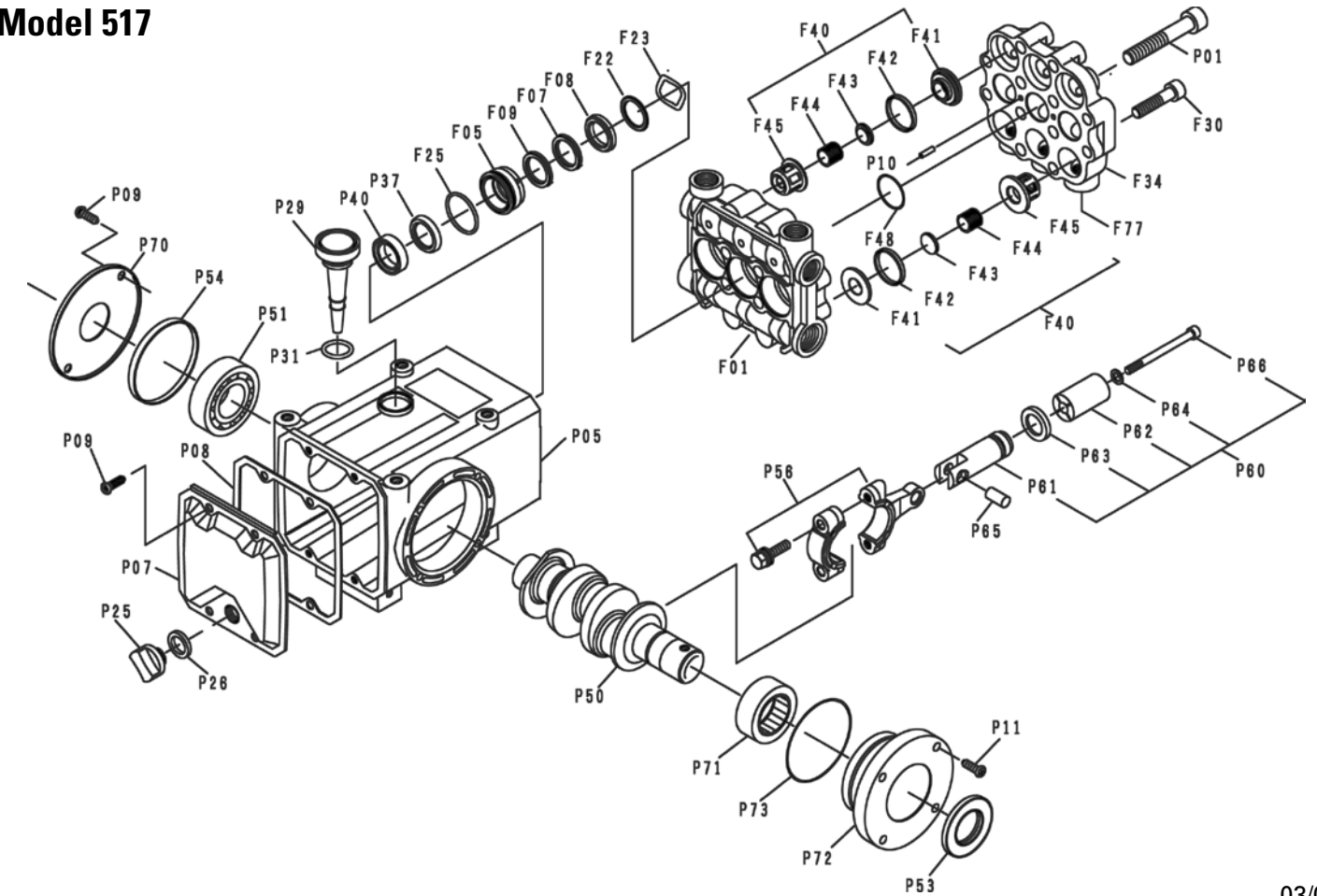

03/07

REF. #	PART NUMBER	PART NAME	MATERIAL	QTY
	30100	SEAL KIT, (INCLUDES F06, F25)	NBR	1
	30101	VALVE KIT, (INCLUDES F40, F42)	STAINLESS/NBR	2
	30102	RAIL, 5 SERIES	PLATED STEEL	2
	30103	OIL, BOTTLE (32 OZ) ISO 100		1
Recommended Accessories				
	70200	6085 REGULATOR, 5 gpm, 1200 PSI	BRASS	1

### Horsepower Requirements

### Pressure (psi)

517	RPM			Pressure (psi)				
	GPM	LPM		750	1000	1250	1500	1750
	600	1.7	6.4	0.8	1.1	1.4	1.7	2.0
	1200	3.4	12.8	1.7	2.2	2.8	3.4	3.9
	1800	5.0	19.2	2.5	3.4	4.2	5.0	5.9

\* Material listed may be a proprietary version. Parts names without part numbers are only available within complete assemblies.

\* Material codes: FP=Fluoropolymer, NBR=Medium Nitrile (Buna-N), STAINLESS=Stainless Steel (300 Series)